

Understanding IP Video for
Dealers
Users
Managers
Installers
Engineers
Salespeople

Presented by
SecuritySales
& INTEGRATION

Part 4 of 4

Brought to You by



Time to Pull It All Together



By Bob Wimmer

Principal
Video Security Consultants
cctvbob@aol.com

AT A GLANCE

- Main criterion for all cameras in outdoor applications is: How much light (minimum illumination) does the camera sensor require to produce an acceptable image?
- Also important is the distance requirement of the camera location to the system switch; the maximum distance of any network from an IP-based camera to the first switch should be about 100 meters
- Transmission medium, or cabling type, is another crucial application determinant, with fiber being mostly superior to “Category” and coax cabling
- Bandwidth, image size and features such as automatic gain control and backlight compensation play a major role
- Final application consideration is whether video is to be used for general, safety or identification purposes

Deploying IP cameras necessitates not only an indoctrination of networking concepts, but also a firm grasp of analog video and how to translate those design principles into the language of digital surveillance. Sizing up an application calls for equal consideration of a range of factors, such as purpose, location, light, bandwidth and image size.

Welcome to Part IV — the final chapter — of the latest in *Security Sales & Integration's* acclaimed “D.U.M.I.E.S.” series: “Understanding IP Video for D.U.M.I.E.S.” Brought to you by Pelco, this four-part series has been designed to educate readers about networked video — the next phase of surveillance technology following the quantum leap from analog to digital CCTV systems. “D.U.M.I.E.S.” stands for dealers, users, managers, installers, engineers and salespeople.

In Part I of this year's series (see “Using Camera Specs to Solve IP Application Issues” in the March issue), we discussed the design of cameras, their specifications and how it relates to IP cameras as well as their networks. We also discussed how to determine the quality of cameras and whether they are designed for indoor or outdoor applications.

In Part II (see “Clear Eye for the IP Video Guy” in the May issue), we investigated ways to enhance IP camera image quality and basic system layouts. The material also addressed how image file sizes as well as bit rates affect both system bandwidth requirements and the amount of storage required for different applications.

In Part III (see "Clearing Up Compression Misconception" in the August issue), took it all a step further by explaining the need for video bandwidth compression and the different methods used in reducing system bandwidth for use on any IP network.

This month's lesson brings the entire process to its logical conclusion by explaining and exploring several different types of applications, and assessing the pros and cons of the deployment of IP-based video cameras given a broad range of parameters and specifications.

Placement, Light Are Critical Points

The first step in determining the type of IP-based camera equipment required for any project is determining whether the application is indoors or outdoors.

5 Key Application Questions

1. Indoors?
2. Outdoors?
3. Distance?
4. Resolution?
5. Images per second?

The main selection information for all cameras in outdoor applications is: How much light does the camera sensor require to produce an acceptable image?

As discussed in Part I of this series, whether it is analog or IP-based, by design the camera requires some information from the manufacturer in order to make the proper determination. Most IP-based cameras are designed for indoor or brightly lit areas. When camera equipment is required for low light or outdoor applications, some additional information is needed.

The main selection information for all cameras in outdoor applications is: How much light does the camera sensor require to produce an acceptable image? This information can be found on the camera specification sheet. The

Typical IP-Based Camera Specifications

P/T/Z MPEG4/JPEG network IP camera

26x optical zoom

pan range of 340° and a tilt range of 115°

"Day/Night" function to provide optimized sensitivity

Minimum illumination

Color: 2.2 lx (50IRE, F1.6, AGC ON),

B/W: 0.3 lx (50IRE, F1.6, AGC ON)

- Fully configurable MPEG4 compression engine
- Optimal synchronization of audio and video
- Motorized pan and tilt capability with click-to-move on image
- 64/128-bit WEP encryption
- Built-in intelligent motion detection

The best way to find out about the capabilities, functions and limitations of an IP camera is by inspecting its specification sheet. One of the key specs, particularly if the camera is to be deployed in a lighting-compromised location, is *minimum illumination*.

line you need to locate on the data sheet is called *minimum illumination*.

An example of a minimum illumination specification would be:

Sensitivity of 1.1 lux (0.11 fc), F1.2 lens @40 IRE

As a quick note, if this item is not mentioned or listed on the IP camera's specification sheet, that camera is not designed for low-light applications.

Another main area for discussion is the distance requirement of the camera location to the system switch. For many first-timers this can be confusing, especially if they come from a standard CCTV background. According to network standards, the maximum distance of any network from an IP-based camera to the first switch is approximately 100 meters (~300 feet).

The distance requirement is not much of a concern for interior system applications. However, in outdoor applications, this distance requirement must not be overlooked.

As an example, a complete IP-based surveillance system that includes both interior and exterior locations may have to incorporate two or three different transmission methods. These methods will consist of Category-grade

network wiring (Cat-5, -5e, -6), standard coaxial cable (RG-59, -6, -11/u), or fiber optics (multimode).

When to Apply 'Category' Cabling

Let's take a closer look at the assorted types of Category cabling and their relationship to applications.

Category-5 — The original specification for Cat-5 cable was defined in ANSI/TIA/EIA-568-A. These specified the performance characteristics and test requirements for frequencies of up to 100MHz. Cat-5 cable typically has three twists per inch of each twisted pair, comprised of 24-gauge copper wires within the cable. It may be unsuitable for 1000BASE-T gigabit Ethernet.

Category-5e — Cat-5e cable is an enhanced version of Cat-5 that adds specifications for far-end crosstalk. It was formally defined in 2001 in the TIA/EIA-568-B standard, which no longer recognizes the original Cat-5 specification. Although 1000BASE-T was designed for use with Cat-5 cable, the tighter specifications associated with Cat-5e and connectors make it an excellent choice for use with 1000BASE-T. Cat-5e cable does not enable longer cable distances for Ethernet

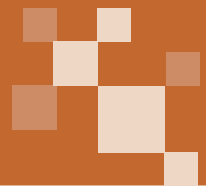

Block Diagram of Multiple Video Transmission Methods

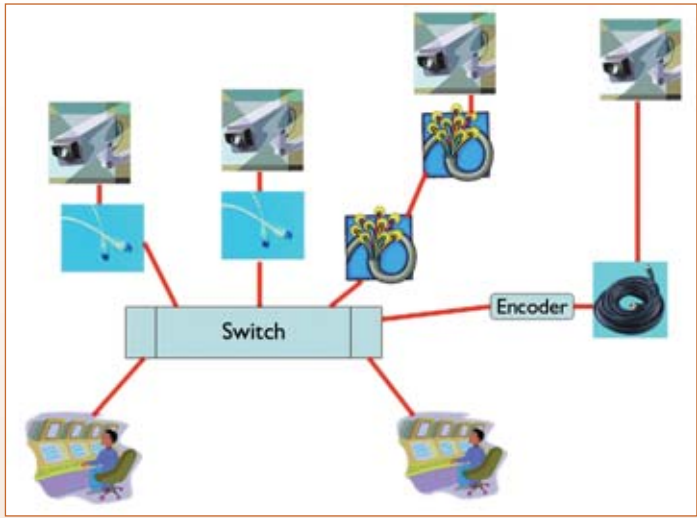

A complete IP-based surveillance system that includes both interior and exterior locations may have to incorporate two or three different transmission methods. These methods will consist of Cat-grade network wiring, standard coax cable and/or fiber optics.

networks; cables are still limited to a maximum of 100m (328 feet) in length.

Category-6 — Cat-6 is a cable standard for gigabit Ethernet and other network protocols that is backward compatible with the Cat-5/5e and Cat-3 cable standards. Cat-6 features more stringent specifications for crosstalk and system noise. The cable standard provides performance of up to 250MHz and is suitable for 10BASE-T / 100BASE-TX and 1000BASE-T (gigabit Ethernet).

The cable contains four twisted copper wire pairs, just like earlier copper cable standards. Although Cat-6 is sometimes made with 23-gauge wire, this is not a requirement.

All of these cables are still limited to 100 meters. So what happens to the camera application that exceeds these distances? Placing a hub station in the middle of a parking lot may not be the best solution. So what else is available? The answer is coaxial cable or fiber optics.

This selection between coaxial cable and fiber optics is normally based on the overall maximum dis-

tance requirements. If the distance is between 1,000 to 1,300 feet, the incorporation of a network encoder associated with a standard analog camera may be an answer.

Coaxial Vulnerable to Interference

Coaxial cable is an electrical cable consisting of a round conducting wire, surrounded by an insulating spacer, surrounded by a cylindrical conducting sheath, usually surrounded by a final insulating layer. Despite all these layers and craftsmanship of design, there are some disadvantages to using coax.

The first is the possibility of interference, especially when the cables are located in high noise areas. Also, the cable offers a greater attenuation over distance and may cause poor signal quality at the encoder. Using only high quality coaxial cable will greatly help this situation.

Pricing can also be an issue. A quick review will show the price between an IP-based camera and an analog camera with an encoder is very similar. As for the performance, well again it will depend on the quality of the cable and installation practices.

The last option for an extended distance application is the utilization of fiber optic.

Fiber Offers Fantastic Features

In recent years, it has become apparent that fiber optics is steadily replacing copper wire as an appropriate means of communication signal transmission. It spans the long distances between local video systems as well as provides the backbone for many network systems.

A basic fiber-optic system consists of a transmitting device, which generates the light signal; an optical fiber cable, which carries the light; and a receiver, which accepts the light signal transmitted. The fiber itself is passive and does not contain any active, generative properties.

Most people still refuse to incorporate fiber optics because of a preconceived

Cabling Distance Limitations Comparison

| | |
|---------------|---|
| Cat-5e | 328 feet |
| Coaxial cable | 500-750 feet (RG-59/U) 1,000 feet (RG-6/U) |
| Fiber optics | 5,000-10,000 feet (multimode) |

Selecting between coaxial cable and fiber optics is normally based on the overall maximum distance requirements. If the distance is between 1,000 to 1,300 feet, the incorporation of a network encoder associated with a standard analog camera may be an answer.

notion that fiber is very expensive and complicated to install. However, the growth of IP-based networked systems, the advantages of fiber, plus manufacturers' increasing adaptability to fiber, has caused a rise in the number of installations. Today, it is appropriate for the use of fiber optics to be considered as a method to transmit

information in networked security applications in projects large and small.

Fiber optics offers capabilities well beyond those of coaxial cable without the high cost and restrictions of other mediums. High bandwidth, low noise and electromagnetic immunity are probably the three most outstanding features of fiber optics.

Since optical fiber is a nonmetallic conductor, it is not affected by elec-

Advantages of Fiber Optics

- ✓ Not affected by Electromagnetic Interference (EMI)
- ✓ Not affected by Radio Frequency Interference (RFI)
- ✓ Not affected by high voltage
- ✓ Not affected by induced voltage (ground loop)
- ✓ Works over extended distances
- ✓ Offers higher degree of security
- ✓ Accommodates large bandwidth

In recent years, it has become apparent that fiber optics is steadily replacing copper wire as an appropriate means of communication signal transmission. It spans the long distances between local video systems as well as provides the backbone for many network systems.

tromagnetic (EMI) or radio frequency (RF) interference. These properties enhance the performance of the fiber system. As more and more system installations demand higher electrical energy standards, such characteristics are making fiber optics well suited for modern-day installations.

Another main, well-known electrical advantage is that fiber optics eliminates ground loops that cause problems in more than 60 percent of all the security systems wired with standard coaxial cable. Ground loops cause major distortion problems for video, audio, as well as networks.

The reason for ground loops is simple; coaxial cable uses current rather than light to transmit information and this current can cause differences of

electrical potentials, especially in larger systems or systems incorporating long cable runs. This elimination of ground loop correctors can greatly reduce the overall cost of any installation.

All of these features add up to reduced noise and greater system bandwidths.

Managing Bandwidth Issues

The next area for consideration for proper operation is asking whether the systems' backbone can handle the traffic requirement of the application. The fact is that different media supports different bandwidth capabilities.

Network hardware manufacturers have done a great job of promoting the concept of *bandwidth*. Virtually everyone knows the bandwidth rating of their system. Essentially, bandwidth is the total amount of data that can be transmitted via the cable per second. Obviously, the greater the capacity, the greater the performance, the greater the number of cameras and the higher the quality of the video.

When installing cable in a network, care should be taken to install the cable that will fill both current network-loading requirements, and future expansion needs. Replacing cabling when it cannot support new

equipment is far more expensive than installing a higher bandwidth cable during initial construction.

In general, fiber-optic cable can support the greatest bandwidth (upwards of 25,000 gigabits) and UTP (unshielded twisted pair) has the lowest. UTP and STP (shielded twisted pair) cables are designed to carry different levels of bandwidth. Cat-5 cabling, which is the most popular cabling installed today, can handle up to 1,000MB. However, at this speed, maximum distance between network segments is reduced. As these distances vary due to cable construction, check with your cabling supplier to verify the maximum bandwidth supported by your cable, and the maximum distance per segment supported at the different speeds.

A number of tools exist for computer networkers to measure the bandwidth of network connections. On LANs (local area networks), these tools include netperf and ttcp. On the Internet, numerous "bandwidth test" or "speed test" programs exist, many of which are made available for interactive use through public Web pages. Anyone who uses these programs quickly learns that bandwidth is a

Large Vs. Small Bandwidth Comparison

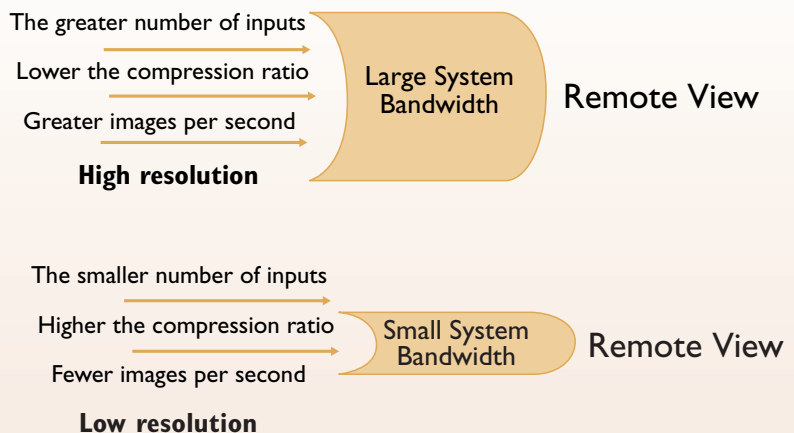

Essentially, bandwidth is the total amount of data that can be transmitted via the cable per second. Obviously, the greater the capacity, the greater the performance, the greater the number of cameras and the higher the quality of the video.

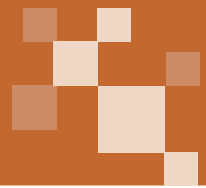

Video Application Purpose and Location

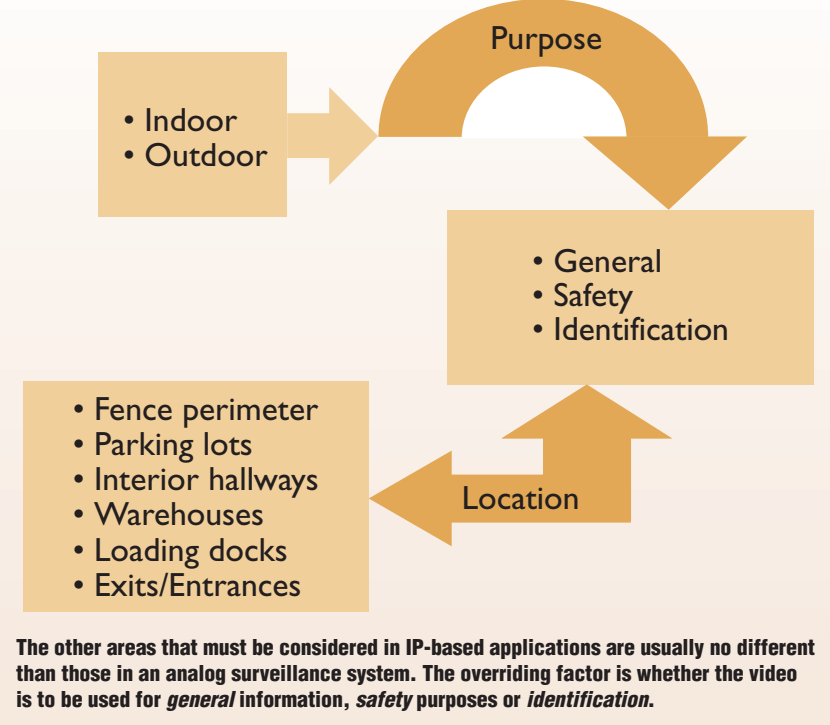

highly variable quantity that is difficult to precisely measure. In a nutshell, typical network architectures involve multiple layers of hardware and software, as well as timesharing.

Defining the Purpose of the System

What other areas must be considered in all IP-based applications? This question comes up many times doing analog conversions. These considerations are usually no different than the consideration one finds in an analog surveillance system. The overriding factor is whether the video is to be used for *general* information, *safety* purposes or *identification*.

IP-based cameras offer software programs in which the user can adjust the output parameters of the video stream. As for a little background, analog or composite output cameras output video at a rate of 30 frames or 60 fields per second. The input to any digital device such as a DVR only selects the number of images they want

to record. A system operator or administrator of the DVR usually sets this parameter. The terms used to describe the number of recorded images are listed as real-time, real-motion or time-lapse video and, in some circles, are called the image record rate.

As previously mentioned, this parameter is set via software in the IP camera. But what should the rate be? This depends on what the purpose is for the surveillance system. General-purpose applications may only require an image rate of 3 to 4 ips (images per second) for full safety. For complete identification, the rate may have to be increased. Many applications now require the image rate to exceed 15 ips to qualify.

The drawback for a network is system bandwidth. The greater the number of images set by each IP-based camera over the same network, the greater the bandwidth requirement.

On the other side of the coin is the drawback of transmitting or recording

at less than 15 ips, which results in jerky movement for human vision. The blurred or jerky movement is due to the light persistence of the human eye. In many circles, 30 frames or 60 images viewed by the human eye is referred to as real-time video.

Images reproduced at a rate of 15 to 18 are called real-motion video. This number of images produces movement without any jerky motion (although this also depends on age). Any image rate less than 15 ips will result in a loss of a constant movement, which can result in poor recovery of recorded information.

Image Quality Is a Delicate Balance

What about image quality? In the analog world, video quality was listed as *resolution*. In the IP-based world, this is rated in *pixels* (picture elements). Greater pixel count, both in the horizontal and vertical direction, indicates the quality of the network image. Digital or IP-based cameras list the image quality in CIF formats.

CIF (Common Intermediate Format) is a standard video format used in videoconferencing. CIF formats are defined by their resolution and standards both above (2CIF / 4CIF) and below (QCIF / SQCIF) with CIF being the original established resolution ref-

Common Intermediate Format

| | |
|-------------------------|---------------|
| SQCIF (Sub-quarter CIF) | 128 X 96 |
| QCIF (Quarter CIF) | 176 X 144 |
| CIF (Full CIF, FCIF) | 352 X 288 |
| 4CIF (4 X CIF) | 704 X 576 |
| 16CIF (16 X CIF) | 1,408 X 1,152 |

CIF is a standard video format used in videoconferencing. It is defined by its resolution and standards both above (2CIF / 4CIF) and below (QCIF / SQCIF) with CIF being the original established resolution reference. The original CIF is also known as Full CIF (FCIF).

erence. The original CIF is also known as Full CIF (FCIF).

Full CIF uses a 30 fps specification with a resolution per frame of 288 lines containing 352 pixels each. Multiplying 352 and 288 yields 101,376 total pixels in the CIF format, which is exactly four times the number of pixels contained in a QCIF frame (25,344). The "Quarter" terminology is meant to indicate that QCIF frames contain a quarter as many pixels as the CIF

crease the sensitivity of the camera during low-light level applications.

However, what role does AGC play relative to IP-based systems? This feature is a compromise. It amplifies the video signal to improve image strength, but at the same time it also amplifies the noise generated by the circuitry within the camera. This amplification of noise causes not only a grainy image but also will affect the file size of the networked video.

scene. Without this compensation, the scene would otherwise be obscured by blooming or silhouetting.

Some of the newer camera designs have improved this feature and renamed it as wide dynamic range (WDR). Let's take a closer look at how it works.

While a camera's automatic exposure control tries to get the lightness of an image to appear as the human eye would see a scene, it can be easily fooled. Think of the case where a person walks into a fairly dark room with a flashlight in their hand and directs this flashlight to the camera. Although the light source is quite small, it makes the camera believe the scene has become brighter and the camera's lens will try to adjust, resulting in a darkened overall image.

To avoid this, BLC (a.k.a. WDR) circuitry has been introduced. It strives to ignore small areas of high illumination, just as if they were not present at all. The resulting image enables the person to be visually seen and identified. Without backlight compensation, the image would be too dark, and identification would be next to impossible.

IP Ready Means to Be Future Ready

With IP-based cameras finding their way into the mainstream of video surveillance, locations of cameras are no longer just for controlled applications, and can now include fence perimeter; parking lots; interior hallways; warehouses; loading docks; exits/entrances; and more.

Hopefully, you will find that being armed with the information presented in these past four articles will prove to be of great usefulness in your never-ending search to understand and master the world of IP-based and networked video systems. ■

Robert (Bob) Wimmer is president of Video Security Consultants and has more than 35 years of experience in CCTV. His consulting firm is noted for technical training, system design, technical support and overall system troubleshooting.

Digital Image Quality by Pixels

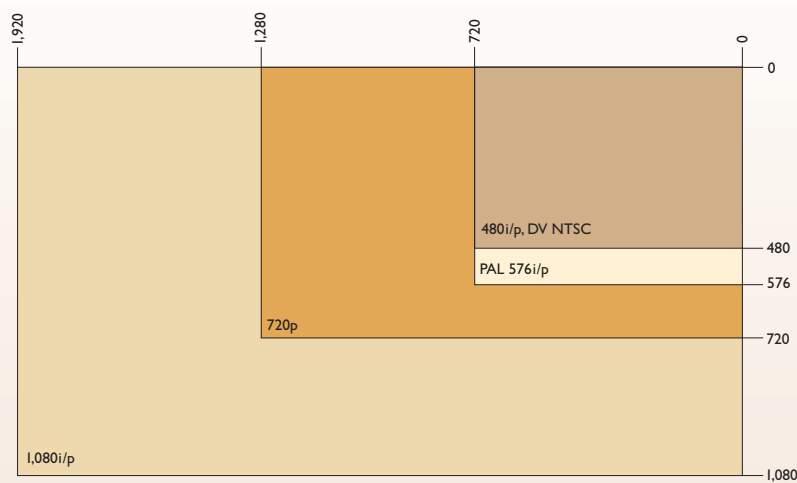

In the analog world, video quality was listed as *resolution*. In the IP-based world, this is rated in *pixels* (picture elements). Greater pixel count, both in the horizontal and vertical direction, indicates the quality of the network image.

frame and, thus, take up less bandwidth in any networked system.

How AGC, BLC Impact Location

The last area in our system application addresses some of the added features found in today's IP-based cameras. These features are used to enhance the video performance in the many different locations that exceed normal camera parameters. However, some of these features can also greatly affect the system's overall bandwidth.

The first feature is *automatic gain control* (AGC), of which many of you are probably already familiar. For those who are unfamiliar with the function of AGC, its purpose is to in-

crease the sensitivity of the camera during low-light level applications. As an example, a normal indoor scene with good lighting and no movement using MPEG compression would require 15kbps per image. This same scene under low-lighted conditions that would require AGC would increase the image size to greater than 198kbps.

This feature must be considered when designing a network backbone, especially if the application includes low light or outdoor requirements.

Another feature found on many IP-based camera data sheets is the known as BLC (backlight compensation). This accounts for the inability of a camera to compensate in cases where a subject with a large amount of background light is introduced into the